

# VOLKSWAGEN

## 2006-10 Passat 3.6L

### PRECAUTIONS

**Warning:** Acid has strong corrosive properties. If batteries are handled inappropriately, there is a risk that personal injury may result from exposure to harmful electrolyte influences. Therefore, suitable remedies for acid damage must be kept readily available. Soapy water would be a suitable remedy.

**Warning:** If electrolyte drips out from the battery, skin can be burned by acid, and the vehicle may be affected by acid erosion and corrosion. It is a possibility that safety-related vehicle components can be damaged.

**Warning:** The gas resulting from charging and partially after charging is explosive. In extreme cases, if the battery is handled inappropriately, the emitted gases may cause the battery to explode.

**Warning:** Producing sparks by sanding, welding, cutting and open flames, as well as smoking near a battery is forbidden. Producing sparks through electrostatic discharge must also be avoided. Always touch the vehicle body before touching the battery.

**Warning:** Only perform battery procedures in suitable and well-ventilated locations.

Always ensure vehicle electrical system is protected by disconnecting battery ground terminal prior to servicing key areas of the electrical system. Disconnecting battery positive terminal must only be performed as required to remove battery from vehicle and must only be carried out after ground terminal is disconnected.

The battery is installed in the lefthand side of the luggage compartment.

### BATTERY

#### Removal

1. Record radio anti-theft code and station presets.
2. Turn off all lamps and accessories.
3. Turn ignition switch to OFF position.
4. Remove luggage compartment service cover (1) from side trim panel (2) in direction of arrow, **Fig. 1**.

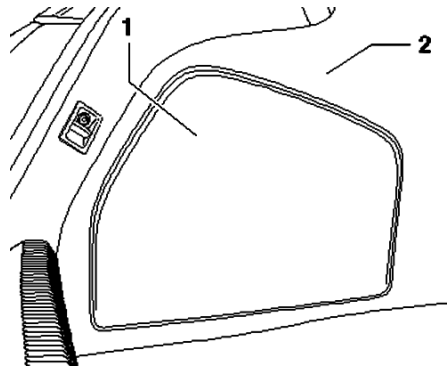

**Fig. 1 Service cover removal**

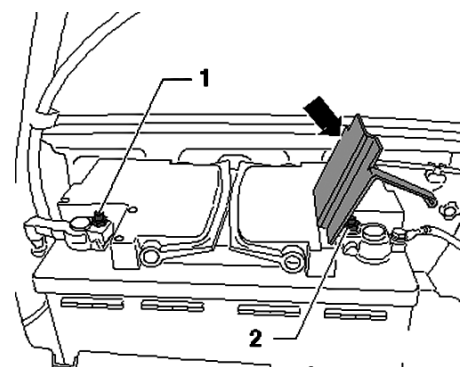

**Fig. 2 Battery cable removal**

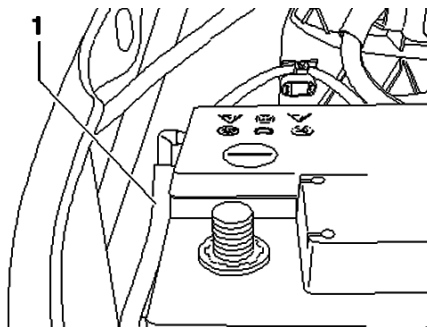

**Fig. 3 Central venting hose removal**

5. Loosen and remove battery ground cable (1) from battery ground terminal, **Fig. 2**.
6. Open pole cover (arrow) over battery positive cable, **Fig. 2**.
7. Loosen and remove battery positive cable (2) from battery positive terminal, **Fig. 2**.
8. Remove central venting hose (1) from battery connection, **Fig. 3**.
9. Remove battery mounting bolt (1), **Fig. 4**.
10. Remove battery hold down (2), **Fig. 4**.
11. Fold up handles (arrows) and remove battery, **Fig. 5**.

### Installation

1. Install battery and ensure it is fully seated.
2. Install battery hold down (2), **Fig. 4**.
3. Install battery mounting bolt (1), and **torque** to 25 ft. lbs., **Fig. 4**.
4. Install battery positive cable (2) to battery positive terminal, and **torque** to 53 inch lbs., **Fig. 2**.
5. Install battery ground cable (1) to battery ground terminal, and **torque** to 53 inch lbs., **Fig. 2**.
6. Install central gas venting hose, ensuring that central gas venting hose (1) is inserted into rubber grommet (2) and is not kinked after installation, **Fig. 6**.
7. Install luggage compartment service cover (1) to side trim panel (2), **Fig. 1**.
8. Reset all preset and theft codes previously recorded to radio.
9. Inspect any affected system or component such as clock, comfort adjustment, or compass for proper settings, and adjust as required.

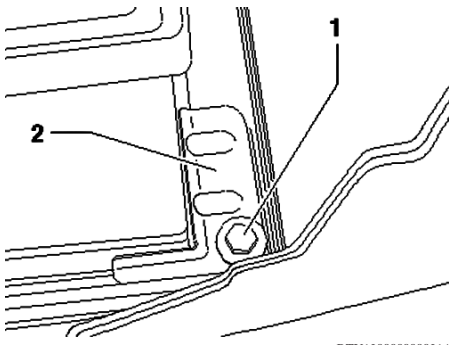

Fig. 4 Battery hold down removal

BTY120000000214

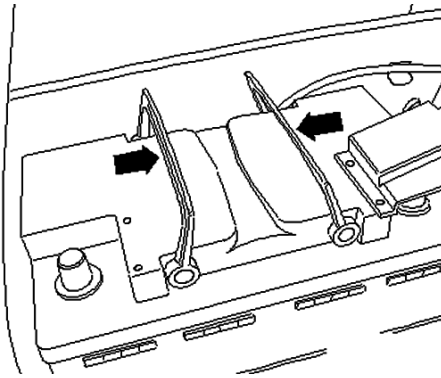

Fig. 5 Battery removal

BTY120000000215

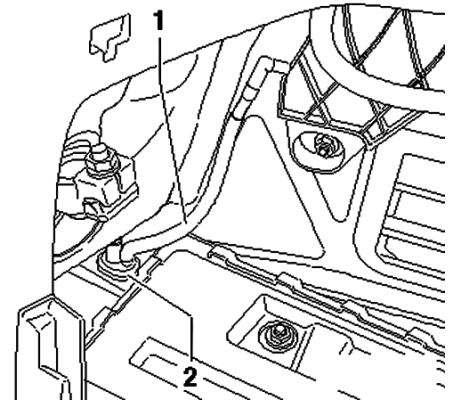

Fig. 6 Central gas venting hose installation

BTY120000000216

The material herein may not be used without the prior express written permission of the copyright holder, including, but not limited to reproduction or transmission in any form by any means such as electronic, mechanical, photocopying, recording or otherwise; nor may it be stored on any retrieval system of any nature.

"The data reported herein has been compiled from authoritative sources. While every effort is made by the analysts to attain accuracy, manufacturing changes as well as typographical errors and omissions may occur on occasion. The publisher cannot be responsible nor does it assume any responsibility whatsoever for such omissions, errors or changes."

"Portions of materials contained herein have been reprinted under license from Volkswagen of America, Inc., License Agreement 08500VWA."

**MOTOR INFORMATION SYSTEMS**  
**MOTOR is a trademark of Hearst Business Media**  
**A Unit of Hearst Corporation**  
**1301 W. Long Lake, Suite 300**  
**Troy, MI 48098**

Copyright © 2012 Hearst Business Media. All rights reserved.