

# MERCEDES-BENZ

## 1998-2003 ML320

### PRECAUTIONS

**Warning:** Risk of explosion when charging lead batteries with battery electrolyte containing sulfuric acid. A highly explosive gas mixture is created that ignites by means of fire, sparks, open flames and smoking.

**Warning:** The battery electrolyte contains diluted sulfuric acid that causes caustic burns to the skin, eyes and mucous membranes in the event of contact. Bonded electrolyte is just as caustic as liquid electrolyte. Battery electrolyte mist causes caustic burns to eyes. If inhaled, this can result in caustic burns to mucous membranes and respiratory tracts.

**Warning:** In event of a short circuit from battery positive to ground, battery terminals and conductive objects causing short circuit, such as a tool or jewelry, become hot in seconds and cause burns.

**Warning:** If battery electrolyte is swallowed, this can result in symptoms of poisoning such as headache, dizziness, stomach ache, respiratory paralysis, unconsciousness, vomiting, caustic burns and cramps. Absorption of lead in body through contact with leaded components (battery terminals, lead plates in damaged batteries) damages blood, nerves and kidneys; lead compounds are also toxic for reproduction.

**Caution:** Wear acid-resistant gloves and clothing and safety glasses with side guards.

Only charge lead batteries in well-ventilated rooms with appropriate voltage and appropriate current with approved chargers, taking into account the instructions of battery and charger manufacturers.

**Caution:** Do not place any conductive objects on battery and do not wear any conductive jewelry (risk of short circuit).

Always disconnect the ground terminal first; always connect positive terminal first (risk of short circuit caused by tool).

Only store, transport and install batteries with liquid battery electrolyte horizontally, otherwise battery electrolyte can escape from the degassing holes.

### BATTERY

#### Removal

1. Open and support engine hood.
2. Turn ignition key to "0" position.
3. After opening vehicle, wait for at least four minutes before disconnecting battery, otherwise alarm will be triggered.

4. Remove nut (5) and disconnect battery ground cable. Insulate terminal of ground cable to avoid unintentional contact between ground cable (1) and ground point (W16/4). Connect quiescent current retention unit if required, **Fig. 1**.
5. Remove protective shield at positive pole of battery, and remove all lines attached to positive cable (2), **Fig. 2**.
6. Disconnect positive line (2) from battery (G1), **Fig. 2**.
7. Remove seal (3) at shield (4), **Fig. 2**.
8. Remove bolt for securing generator line to shield, if required.
9. Slacken retaining clip at side of shield (4), guide all lines through shield, and lay to one side, **Fig. 2**.
10. Detach coolant circulation pump (M13) from shield, if required, **Fig. 2**.
11. Remove cable strap at lines at side of shield.
12. Detach overflow hose (8) and control cable (9) at shield, **Fig. 2**.
13. Detach fuse holder for suction fan (10) at front of shield, and remove line from shield if equipped, **Fig. 2**.
14. Remove bolt (11) at shield, **Fig. 2**.
15. Remove clamping wedge (12) at retaining bracket, **Fig. 2**.
16. Detach retaining bracket (13) by pressing downward, **Fig. 2**.
17. Detach and remove shield (4), turn shield forward, and reset in order to loosen front retaining lugs, **Fig. 2**.
18. Remove battery.
17. If power supply to radio is interrupted, radio will not operate when reconnected. After switching on ignition, "CODE" appears on radio display. Code radio as follows:
  - a. Code number for radio is given on included code card.
  - b. Enter code number with station buttons, e.g. number one is station button one.
  - c. After entering first digit, "CODE" disappears and number entered is displayed followed by four dashes. Enter next numbers with corresponding station buttons. After entering five digit code number, compare code number with number on display. At this point, code number can be written over as frequently as required for correction. If wrong code number has been entered, enter entire code number again.
  - d. Confirm entry of correct code number with "<" or ">" button.
  - e. If wrong code number has been entered and confirmed, "CODE" appears again on display and code must be entered again.
  - f. After entering code incorrectly three times, "WAIT" appears on display and radio is disabled for approximately 10 minutes. After entering incorrect code three times again, radio is disabled for approximately 60 minutes. Disable time runs down only with radio switched off.

### Installation

1. Install battery.
2. Attach and install shield (4), **Fig. 2**.
3. **Torque** shield to body bolt to 15 ft. lbs.
4. Attach retaining bracket.
5. Install clamping wedge at retaining bracket.
6. Attach fuse holder for suction fan at front of shield, and install line from shield, if equipped.
7. Attach overflow hose and control cable at shield.
8. Install cable strap at lines at side of shield.
9. Attach coolant circulation pump to shield, if required.
10. Guide all lines through shield, and tighten retaining clip at side of shield (4), **Fig. 2**.
11. Install bolt for securing generator line to shield, if required.
12. Install seal (3) at shield (4), **Fig. 2**.
13. Connect positive line to battery.
14. Connect all lines that were attached to positive cable, and install protective shield at positive pole of battery.
15. Connect battery ground cable to body.
16. **Torque** ground line to body nut to 13 ft. lbs.
18. Set time on stationary heater time, if required.
19. If battery is disconnected or power supply to steering angle sensor is interrupted, ADS or ESP control module switches to malfunction. ADS or ESP malfunction indicator lamp will come on. It is required to reactivate steering angle sensor to eliminate malfunction. Reactivate steering angle sensor as follows:
  - a. Start engine and allow to idle.
  - b. Turn steering wheel from lock to lock.
  - c. ADS or ESP malfunction indicator lamp should go out.
20. Synchronize tilting/sliding roof, if equipped. Open tilt/slide sunroof and hold down switch. Tilting/sliding roof mechanism moves to end position, pulls back 1/4 turn and stops.
21. Synchronize lamella roof, if equipped. Close lamella roof and hold down switch for five to ten seconds.
22. Synchronize power windows. Press switch for power windows to first actuation point, and then hold down for another five seconds after window has reached its top end position.

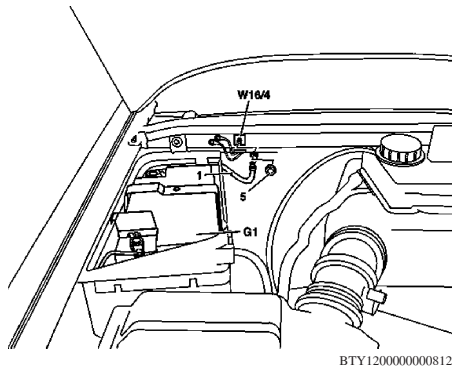

**Fig. 1 Battery ground removal**

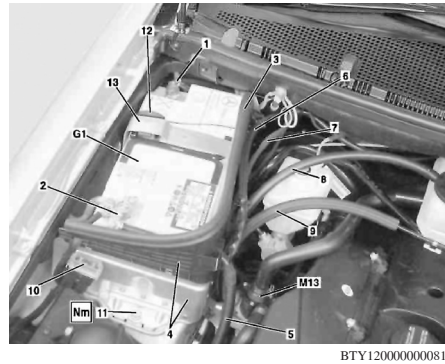

**Fig. 2 Battery removal**

The material herein may not be used without the prior express written permission of the copyright holder, including, but not limited to reproduction or transmission in any form by any means such as electronic, mechanical, photocopying, recording or otherwise; nor may it be stored on any retrieval system of any nature.

"The data reported herein has been compiled from authoritative sources. While every effort is made by the analysts to attain accuracy, manufacturing changes as well as typographical errors and omissions may occur on occasion. The publisher cannot be responsible nor does it assume any responsibility whatsoever for such omissions, errors or changes."

**MOTOR INFORMATION SYSTEMS**  
**MOTOR is a trademark of Hearst Business Media**  
**A Unit of Hearst Corporation**  
**1301 W. Long Lake, Suite 300**  
**Troy, MI 48098**

Copyright © 2012 Hearst Business Media. All rights reserved.