

MERCEDES-BENZ

1994-2000 C280

PRECAUTIONS

Warning: Risk of explosion when charging lead batteries with battery electrolyte containing sulfuric acid, a highly explosive gas mixture is created that ignites by means of fire, sparks, open flames and smoking.

Warning: The battery electrolyte contains diluted sulfuric acid that causes caustic burns to skin, eyes and mucous membranes in the event of contact. Bonded electrolyte is just as caustic as liquid electrolyte. Battery electrolyte mist causes caustic burns to eyes. If inhaled, this can result in caustic burns to mucous membranes and respiratory tracts.

Warning: In event of a short circuit from battery positive to ground, battery terminals and conductive objects causing short circuit, such as a tool or jewelry, become hot in seconds and cause burns.

Warning: If battery electrolyte is swallowed, this can result in symptoms of poisoning such as headache, dizziness, stomach ache, respiratory paralysis, unconsciousness, vomiting, caustic burns and cramps. Absorption of lead in body through contact with leaded components (battery terminals, lead plates in damaged batteries) damages blood, nerves and kidneys; lead compounds are also toxic for reproduction.

Caution: Wear acid-resistant gloves and clothing and safety glasses with side guards.

Only charge lead batteries in well-ventilated rooms with appropriate voltage and appropriate current with approved chargers, taking into account the instructions of battery and charger manufacturers.

Caution: Do not place any conductive objects on battery, and do not wear any conductive jewelry (risk of short circuit).

Always disconnect the ground terminal first; always connect positive terminal first (risk of short circuit caused by tool).

Only store, transport and install batteries with liquid battery electrolyte horizontally, otherwise battery electrolyte can escape from the degassing holes.

BATTERY

Removal

1. Record radio anti-theft code and station presets.
2. Turn off all lamps and accessories.
3. Turn ignition switch to OFF position.
4. Fold trunk cover up.
5. Remove cargo space cover.
6. Remove mounting bolt (1) and battery hold down (2), **Fig. 1**.
7. Disconnect ground cable (3) at battery, **Fig. 1**.
8. Disconnect positive cable (4), **Fig. 1**.
9. Detach vent pipe (5) at battery, **Fig. 1**.
10. Remove battery.

Installation

1. Set battery into position.
2. Attach vent pipe (5) at battery, **Fig. 1**.
3. Connect positive cable (4), **Fig. 1**.
4. Connect ground cable (3) at battery, **Fig. 1**.
5. Install mounting bolt (1) and battery hold down (2), **Fig. 1**.
6. Install cargo space cover.
7. Fold trunk cover down.
8. Code radio as follows:
 - a. Switch on ignition switch; "CODE" will appear in display on radio.

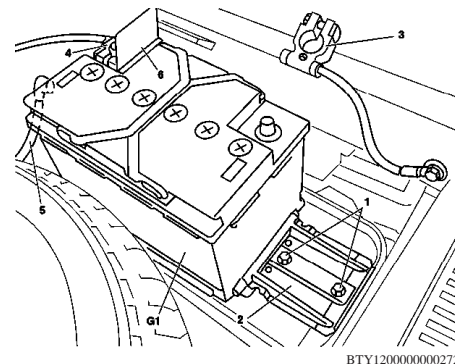

Fig. 1 Battery removal

- b. Retrieve code card supplied with vehicle or radio.
 - c. Enter code number with corresponding station button. If an incorrect code number is entered, "CODE" appears again. If an incorrect code is entered three times, "WAIT" appears on display and radio locks up for approximately ten minutes. If code is entered incorrectly three times again, radio locks up for ten minutes. Three more incorrect entries (a total of nine incorrect attempts) increase lock-up time to 60 minutes.
 - d. Verify correct radio operation.
9. Activate steering angle sensor as follows:
 - a. Start engine and allow to idle.
 - b. Turn steering wheel from lock to lock. ADS or ESP malfunction indicator lamp should go out.
 - c. Turn ignition OFF.
 10. Inspect any affected system or component such as clock, comfort adjustment, or compass for proper settings, and adjust as required.

The material herein may not be used without the prior express written permission of the copyright holder, including, but not limited to reproduction or transmission in any form by any means such as electronic, mechanical, photocopying, recording or otherwise; nor may it be stored on any retrieval system of any nature.

"The data reported herein has been compiled from authoritative sources. While every effort is made by the analysts to attain accuracy, manufacturing changes as well as typographical errors and omissions may occur on occasion. The publisher cannot be responsible nor does it assume any responsibility whatsoever for such omissions, errors or changes."

MOTOR INFORMATION SYSTEMS
MOTOR is a trademark of Hearst Business Media
A Unit of Hearst Corporation
1301 W. Long Lake, Suite 300
Troy, MI 48098

Copyright © 2012 Hearst Business Media. All rights reserved.