

# ISUZU 2006 i-280

## PRECAUTIONS

**Warning:** Batteries produce explosive gases. Batteries contain corrosive acid. Batteries supply levels of electrical current high enough to cause burns.

**Caution:** In order to reduce the risk of personal injury while working near a battery, always shield your eyes, avoid leaning over battery whenever possible, do not expose battery to open flames or sparks, and do not allow battery acid to contact eyes or skin.

**Caution:** Before servicing any electrical component, ignition key must be in OFF or LOCK position and all electrical loads must be OFF, unless instructed otherwise in these procedures. If a tool or equipment could easily come in contact with a live exposed electrical terminal, also disconnect battery ground cable. Failure to follow these precautions may cause personal injury and/or damage to vehicle or its components.

## BATTERY Removal

1. Record radio anti-theft code and station presets.
2. Turn off all lamps and accessories.
3. Turn ignition switch to OFF position.

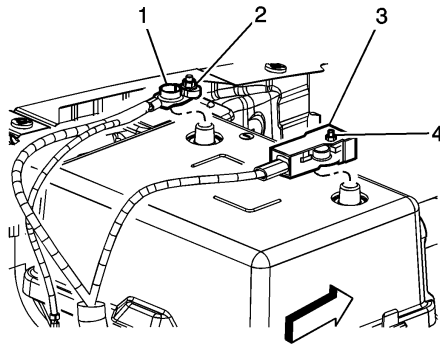

**Fig. 1 Battery cable removal**

4. Loosen battery ground cable nut (2), **Fig. 1**.
5. Disconnect battery ground cable (1) from battery, **Fig. 1**.
6. Open protective cover (3) to access battery positive cable terminal, **Fig. 1**.
7. Disconnect battery positive cable from battery.
8. Disconnect battery vent duct from upper battery box (2), **Fig. 2**.
9. Press locking tabs (1) inward to remove upper battery box (2) from lower battery box (3), **Fig. 2**.
10. Remove battery retainer nut (3), **Fig. 3**.
11. Remove battery retainer (1) and washer (2), **Fig. 3**.

12. Remove battery (4) from lower battery box (5), **Fig. 3**.

## Installation

1. Install battery (4) into lower battery box (5), **Fig. 3**.
2. Install battery retainer (1) and washer (2), **Fig. 3**.
3. Install battery retainer nut (3), and **torque** nut to 11 ft. lbs., **Fig. 3**.
4. Install upper battery box (2) over battery, and engage locking tabs (1) into lower battery box (3), **Fig. 2**.
5. Connect battery vent duct to upper battery box (2), **Fig. 2**.
6. Clean any existing corrosion from battery terminal and battery cable using a wire brush.
7. Connect battery positive cable to battery, and **torque** nut (4) to 80 inch lbs., **Fig. 1**.
8. Close protective cover (3) over battery positive cable terminal, **Fig. 1**.
9. Connect battery ground cable (1) to battery, and **torque** battery cable nut (2) to 80 inch lbs., **Fig. 1**.
10. Reset all preset and theft codes previously recorded to radio.
11. Completely open and close all power windows.
12. Inspect any affected system or component such as clock, comfort adjustment, or compass for proper settings, and adjust as required.

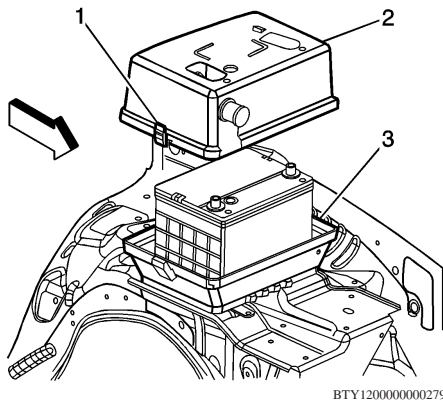

**Fig. 2 Battery box removal**

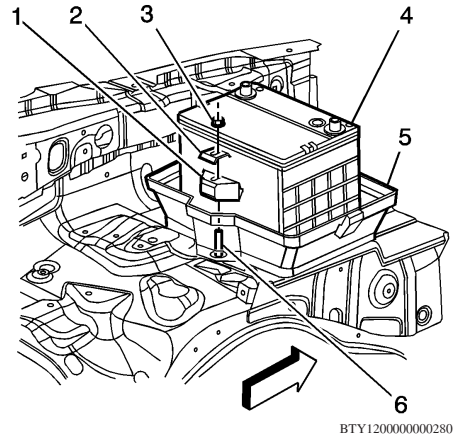

**Fig. 3 Battery removal**

---

The material herein may not be used without the prior express written permission of the copyright holder, including, but not limited to reproduction or transmission in any form by any means such as electronic, mechanical, photocopying, recording or otherwise; nor may it be stored on any retrieval system of any nature.

"The data reported herein has been compiled from authoritative sources. While every effort is made by the analysts to attain accuracy, manufacturing changes as well as typographical errors and omissions may occur on occasion. The publisher cannot be responsible nor does it assume any responsibility whatsoever for such omissions, errors or changes."

---

**MOTOR INFORMATION SYSTEMS**  
**MOTOR is a trademark of Hearst Business Media**  
**A Unit of Hearst Corporation**  
**1301 W. Long Lake, Suite 300**  
**Troy, MI 48098**

Copyright © 2012 Hearst Business Media. All rights reserved.

---