

# HUMMER 2006-07 H3

## PRECAUTIONS

**Warning:** Batteries produce explosive gases, contain corrosive acid, and supply levels of electrical current high enough to cause burns. Therefore, to reduce the risk of personal injury when working near a battery: Always shield your eyes and avoid leaning over the battery whenever possible; do not expose the battery to open flames or sparks; do not allow the battery electrolyte to contact the eyes or the skin; flush immediately and thoroughly any contacted areas with water, and get medical help.

**Warning:** Unless directed otherwise, the ignition and start switch must be in the OFF or LOCK position, and all electrical loads must be OFF before servicing any electrical component. Disconnect the battery ground cable to prevent an electrical spark should a tool or equipment come in contact with an exposed electrical terminal. Failure to follow these precautions may result in personal injury and/or damage to the vehicle or its components.

For vehicles equipped with OnStar® (UE1) with Back Up Battery, the back up battery is a redundant power supply to allow limited OnStar® functionality in the event of a main vehicle battery power disruption to the VCIM (OnStar® module). Do not disconnect the main vehicle battery or remove the OnStar® fuse with the ignition key in any position other than OFF. Retained Accessory Power (RAP) should be allowed to time out or be disabled (simply opening the driver door should disable RAP) before disconnecting power to the OnStar® module in any way while the ignition is ON or with RAP activated may cause activation of the OnStar® Back Up Battery (BUB) system and will discharge and permanently damage the BUB. Once the BUB is activated, it will stay on until it has completely discharged. The BUB is not rechargeable and, once activated, the BUB must be replaced.

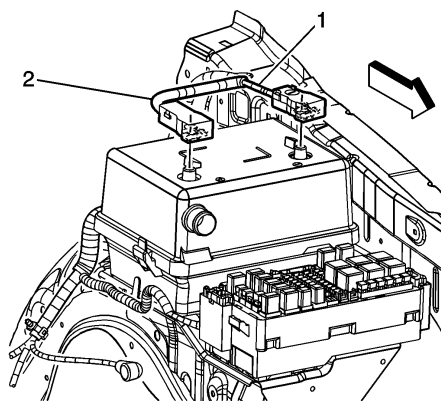

BTY120000000516

**Fig. 1 Battery cable disconnection**

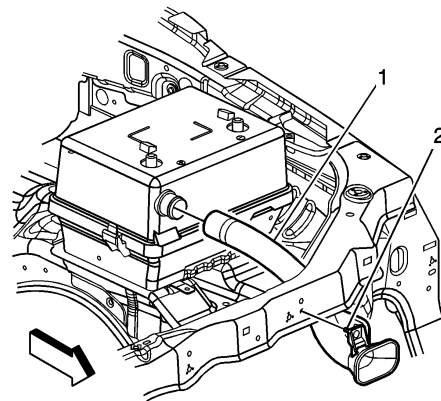

BTY120000000517

**Fig. 2 Battery vent duct removal**

## BATTERY

### Removal

1. Record radio anti-theft code and station presets.
2. Turn off all lamps and accessories.
3. Turn ignition switch to OFF position.
4. Open battery ground cable cover.
5. Loosen battery ground cable nut.
6. Disconnect battery ground cable (1) from battery, **Fig. 1**.
7. Open battery positive cable cover.
8. Loosen battery positive cable nut.
9. Disconnect battery positive cable (2) from battery, **Fig. 1**.
10. Disconnect battery vent duct (1) from upper battery box, **Fig. 2**.
11. Press locking tabs (1) inward, and remove upper battery box (2) from lower battery box, **Fig. 3**.
12. Disengage battery strap pin (2) from battery tray bracket stopper, **Fig. 4**.
13. Remove battery hold down retainer nut (1), battery tray strap (2) and retainer (3), **Fig. 5**.
14. Remove battery from lower battery box, **Fig. 6**.

### Installation

Clean any existing corrosion from the battery terminal and battery cable using a wire brush.

1. Install battery into lower battery box, **Fig. 6**.
2. Install battery hold down retainer (3), battery tray strap (2) and retainer nut (1), **Fig. 5**. **Torque** nut to 11 ft. lbs.
3. Install battery strap pin (2) to battery tray bracket stopper, **Fig. 4**.
4. Install upper battery box (2) over battery, and engage locking tabs (1) into lower battery box, **Fig. 3**.
5. Connect battery vent duct (1) to upper battery box, **Fig. 2**.
6. Connect battery positive cable (2) to battery, **Fig. 1**. **Torque** battery cable nut to 80 inch lbs.
7. Close battery positive cable cover.
8. Connect battery ground cable (1) to battery, **Fig. 1**. **Torque** battery cable nut to 80 inch lbs.
9. Close battery ground cable cover.
10. Reset all preset and theft codes previously recorded to radio.

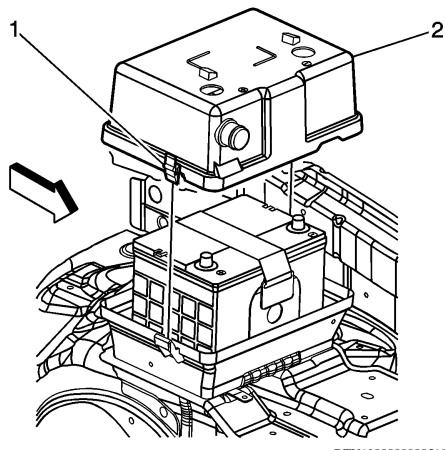

**Fig. 3 Upper battery box removal**

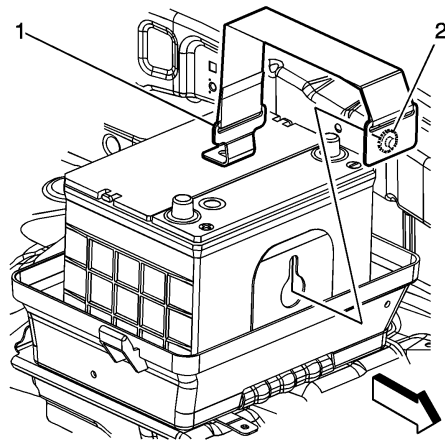

**Fig. 4 Battery strap removal from battery tray bracket stopper**

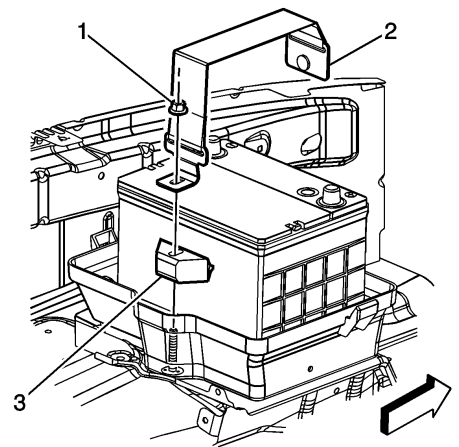

**Fig. 5 Battery tray strap & hold down retainer removal**

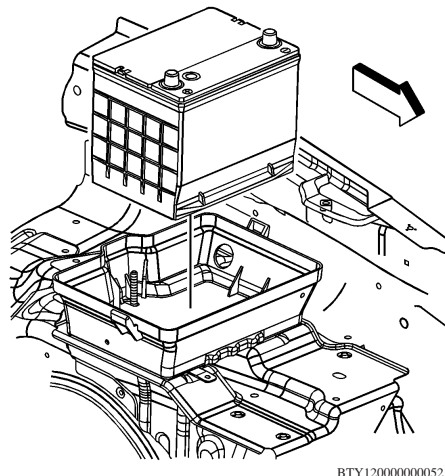

**Fig. 6 Battery removal**

The material herein may not be used without the prior express written permission of the copyright holder, including, but not limited to reproduction or transmission in any form by any means such as electronic, mechanical, photocopying, recording or otherwise; nor may it be stored on any retrieval system of any nature.

"The data reported herein has been compiled from authoritative sources. While every effort is made by the analysts to attain accuracy, manufacturing changes as well as typographical errors and omissions may occur on occasion. The publisher cannot be responsible nor does it assume any responsibility whatsoever for such omissions, errors or changes."

"Portions of materials herein have been reprinted with permission of General Motors Company, Service Technology Group"

**MOTOR INFORMATION SYSTEMS**  
MOTOR is a trademark of Hearst Business Media  
A Unit of Hearst Corporation  
1301 W. Long Lake, Suite 300  
Troy, MI 48098

Copyright © 2012 Hearst Business Media. All rights reserved.