

# FORD

## 2004-10 Econoline 6.0L

### PRECAUTIONS

**Warning:** Keep body from under the auxiliary or secondary battery when disconnecting or reconnecting the auxiliary or secondary battery safety straps, since the battery weighs 50 pounds and bodily injury can result.

**Warning:** Batteries contain sulfuric acid and produce explosive gases. Work in a well-ventilated area. Do not allow the battery to come in contact with flames, sparks or burning substances. Avoid contact with skin, eyes or clothing. Shield eyes when working near the battery to protect against possible splashing of acid solution. In case of acid contact with skin or eyes, flush immediately with water for a minimum of 15 minutes, then get prompt medical attention. If acid is swallowed, call a physician immediately. Failure to follow these instructions may result in serious personal injury.

**Warning:** Always lift a plastic-cased battery with a battery carrier or with hands on opposite corners. Excessive pressure on the battery end walls may cause acid to flow through the vent caps, resulting in personal injury and/or damage to the vehicle or battery.

Failure to accurately follow the battery reconnect procedures outlined will result in vehicle or component damage.

Ford Motor Company strongly recommends that lead-acid batteries be returned to an authorized recycling facility for disposal.

When the battery has been disconnected and reconnected, some abnormal drive symptoms may occur while the Powertrain Control Module (PCM) relearns its adaptive strategy. The vehicle may need to be driven 10 miles or more to relearn the strategy.

If equipped with the CD6 audio unit, precautions must be taken when the battery has been disconnected. When reconnecting the battery, ensure no interruption of power occurs for 30 seconds. If power is interrupted during the first 30 seconds, permanent damage to the CD6 audio unit will result.

### BATTERY

#### Auxiliary

Two 78 ampere-hour, maintenance-free

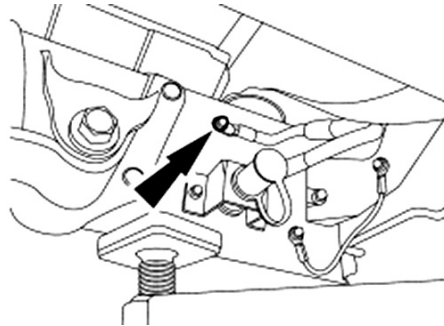

BTY120000000760

**Fig. 1 Secondary battery ground cable disconnection**

batteries are standard with the diesel engine. The secondary battery is connected in parallel with the primary battery and provides more current to the starter motor when cranking and to the vehicle under load. The secondary battery is located on the righthand frame rail to the rear of the B-Pillar.

### REMOVAL

The preferred method of service requires the use of a floor hoist to lift the vehicle overhead and a transmission jack to support and lower the auxiliary or secondary battery case.

1. Disconnect secondary battery ground cable. Be sure to cover ground cable terminal end with electrical tape or with a suitable insulating device, **Fig. 1**.
2. Remove two auxiliary or secondary battery cable harness screws retaining harness to frame, **Fig. 2**.
3. Support bottom of auxiliary or secondary battery and case with a transmission jack.
4. Remove upper righthand auxiliary or secondary case to frame bolt (1), **Fig. 3**.
5. Loosen, but do not remove, three remaining battery case to frame bolts (2), **Fig. 3**.
6. Raise battery case slightly and move away from frame to dislodge battery case from three remaining bolts (3), **Fig. 3**.
7. Remove remaining three battery case to frame bolts (4), **Fig. 3**.
8. Lower auxiliary or secondary battery and case until tension is almost present in auxiliary or secondary battery case safety straps.

9. Remove two auxiliary or secondary battery case cover bolts and disengage battery case cover, **Fig. 4**.
10. Remove auxiliary or secondary battery cables.
11. Remove two auxiliary or secondary battery case safety strap to frame bolts, **Fig. 5**.
12. Disengage auxiliary or secondary battery case safety straps, and roll auxiliary or secondary battery and case away from vehicle.

### INSTALLATION

1. Install auxiliary or secondary battery into case.
2. **Torque** battery hold down clamp bolt to 49–62 inch lbs.
3. Position auxiliary or secondary battery and case on transmission jack under vehicle.
4. Install auxiliary or secondary battery cables.
5. **Torque** cable terminal clamps to 10–13 ft. lbs.
6. Position auxiliary or secondary battery case cover, and install two auxiliary or secondary battery case cover bolts, **Fig. 4**.
7. Lift auxiliary or secondary battery and case, and position for auxiliary or secondary battery case safety strap connection.
8. Install two auxiliary or secondary battery case safety strap bolts, **Fig. 5**.
9. **Torque** safety strap bolts to 25–34 ft. lbs.
10. Align slots in battery case to frame using three bolts. Do not tighten at this time.
11. Move battery case slightly toward frame and lower into position.
12. Install remaining battery case to frame bolt.
13. **Torque** battery case to frame bolts to 25–34 ft. lbs.
14. Install two auxiliary or secondary battery cable harness to frame retaining screws.
15. **Torque** harness to frame retaining screws to 9–11 ft. lbs.
16. Reconnect secondary battery ground cable.
17. **Torque** secondary battery ground cable bolt to 18 ft. lbs.

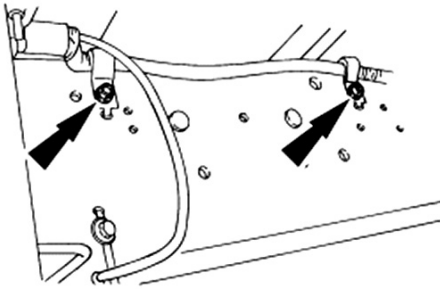

BTY120000000755

**Fig. 2 Secondary battery cable harness removal**

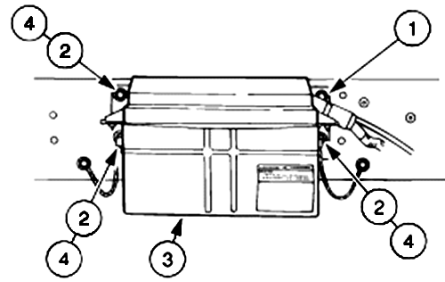

BTY120000000756

**Fig. 3 Secondary battery removal**

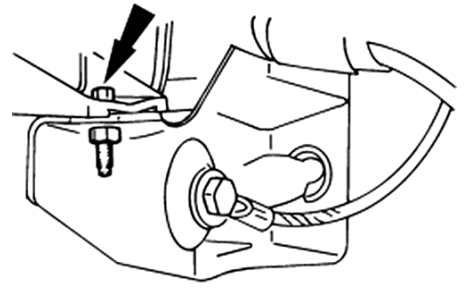

BTY120000000757

**Fig. 4 Battery case cover removal (Part 1 of 2)**

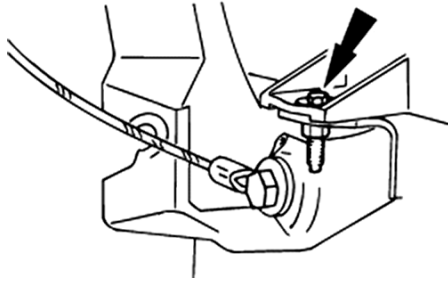

BTY120000000758

**Fig. 4 Battery case cover removal (Part 2 of 2)**

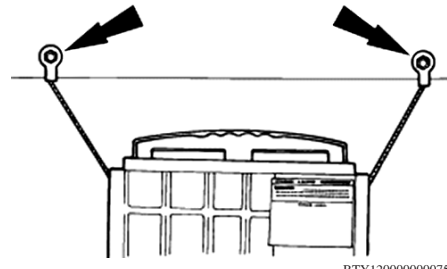

BTY120000000759

**Fig. 5 Battery case safety strap removal**

The material herein may not be used without the prior express written permission of the copyright holder, including, but not limited to reproduction or transmission in any form by any means such as electronic, mechanical, photocopying, recording or otherwise; nor may it be stored on any retrieval system of any nature.

"The data reported herein has been compiled from authoritative sources. While every effort is made by the analysts to attain accuracy, manufacturing changes as well as typographical errors and omissions may occur on occasion. The publisher cannot be responsible nor does it assume any responsibility whatsoever for such omissions, errors or changes."

"This product contains material that is reproduced and distributed under a license from Land Rover, Volvo, Ford & Jaguar. No further reproduction or distribution of this material is allowed without the express written permission of Land Rover, Volvo, Ford or Jaguar."

Ford Data Copyright © 1974-2012 Ford Motor Company

**MOTOR INFORMATION SYSTEMS**  
**MOTOR is a trademark of Hearst Business Media**  
**A Unit of Hearst Corporation**  
**1301 W. Long Lake, Suite 300**  
**Troy, MI 48098**

Copyright © 2012 Hearst Business Media. All rights reserved.