

CHRYSLER

2007-08 Sebring

PRECAUTIONS

Warning: The battery is vented to release excess hydrogen gas that is created when the battery is being charged or discharged. However, even with these vents, hydrogen gas can collect in or around the battery. If hydrogen gas is exposed to flame or sparks, it may ignite. Do not smoke, use flame, or create sparks near the battery. Personal injury and vehicle damage may result. The battery contains sulfuric acid, which is poisonous and caustic. Avoid contact with the skin, eyes, or clothing. In the event of contact, flush with water and call a physician immediately. Keep out of reach of children.

Warning: To protect hands from battery acid, a suitable pair of heavy duty rubber gloves, not the household type, should be worn when removing or servicing a battery. Safety glasses also should be worn. Remove metallic jewelry worn on hands or wrists to avoid injury by accidental arcing of battery current.

Vehicles equipped with a diesel engine utilize a spiral cell battery with recombination technology. This is a maintenance-free battery that is capable of delivering more power than a conventional battery. This additional power is required by a diesel engine during cold cranking. Vehicles equipped with a gasoline engine utilize a conventional battery. **Warning:** When using a high output boosting device or charging, do not allow a conventional battery to exceed 16 volts. Never exceed 14.4 volts when charging a spiral cell battery. Personal injury and/or battery damage may result.

It is important that the battery, starting system, and charging system be thoroughly tested and inspected any time a battery needs to be charged or replaced. The cause of abnormal discharge, over charging or early battery failure must be corrected before a battery is replaced or returned to service.

The battery Group Size number, the Cold Cranking Amperage (CCA) rating, and the Reserve Capacity (RC) rating or Ampere-Hours (AH) rating can be found on the original equipment battery label. Be certain that a replacement battery has the correct Group Size number, as well as CCA and RC or AH ratings that equal or exceed the original equipment specification for the vehicle being serviced.

BATTERY

Removal

This vehicle is equipped with a single 12-volt battery. All of the components of the

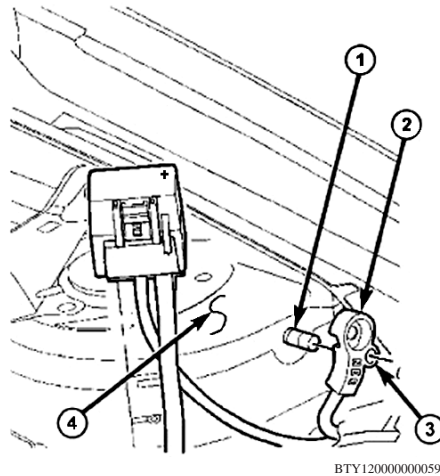

Fig. 1 Battery ground cable remote terminal location

battery system are located in the front of the vehicle, just ahead of the lefthand front wheel and tire assembly.

The battery ground cable remote terminal must be disconnected and isolated from the remote battery post prior to service of the vehicle electrical systems. The battery ground cable remote terminal can be isolated by using the supplied isolation hole in the terminal casing.

Driver side splash shield is a two piece assembly to enable easy access for battery removal.

1. Disconnect battery ground cable remote terminal (2) from remote battery post (1), **Fig. 1**.
2. Raise and support vehicle.
3. Remove lefthand front wheel and tire assembly.
4. Remove forward section of front fender wheelhouse splash shield.
5. Loosen cable clamp nut, and remove positive cable from battery.
6. Remove lower battery tray support bolt (4). Loosen upper support bolt and allow support (1) to swing down out of way, **Fig. 2**.
7. Remove battery hold down bolt (3), **Fig. 2**.
8. Rotate battery hold down rod rearward and disengage it from mounting slot in battery tray (8). Remove battery hold down (2), **Fig. 2**.
9. Partially remove battery from battery tray by sliding it rearward. Properly support battery at all times.
10. Loosen cable clamp nut, and remove battery ground cable from battery.
11. Remove battery from vehicle.

Installation

1. Position battery in battery tray, **Fig. 3**.

2. Connect battery ground cable. **Torque** battery cable clamp nut to 45 inch lbs.
3. Slide battery forward so that it is properly positioned on battery tray.
4. Install battery hold down by engaging rod into mounting slot in battery tray and rotating it forward.
5. Install battery hold down bolt (3), **Fig. 2**. **Torque** hold down bolt to 142 inch lbs.
6. Position rear battery tray support onto battery tray (6), and install lower battery tray support bolt (4), **Fig. 2**. **Torque** both rear battery tray support bolts to 142 inch lbs.
7. Connect battery positive cable. **Torque** battery cable clamp nut to 45 inch lbs.
8. Install forward section of front fender wheelhouse splash shield.
9. Install lefthand front wheel and tire assembly.
10. Lower vehicle.
11. Connect battery ground cable remote terminal (2) from remote battery post (1), **Fig. 1**. **Torque** battery cable clamp nut to 45 inch lbs.

Battery Connection

Once the battery has been connected, review and perform the following information as applicable. These connection procedures are to be performed anytime the battery has been disconnected if the vehicle is equipped with these options.

ELECTRONIC STABILITY CONTROL

If the vehicle is equipped with Electronic Stability Control, also known as Electronic Stability Program (ESP), once the battery is reconnected, the Steering Angle Sensor (SAS) needs to be calibrated. The SAS requires calibration any time the battery or an ABS (ESP) component has been disconnected for any length of time. If the SAS is not calibrated following battery connection, the ESP/BAS indicator lamp is illuminated following five ignition cycles, indicating the need for calibration.

1. Start engine.
2. Center steering wheel.
3. Turn steering wheel in lefthand direction until internal stop in steering gear is met, then turn steering wheel in righthand direction until opposite internal stop in steering gear is met.
4. Center steering wheel.
5. Turn engine "Off."

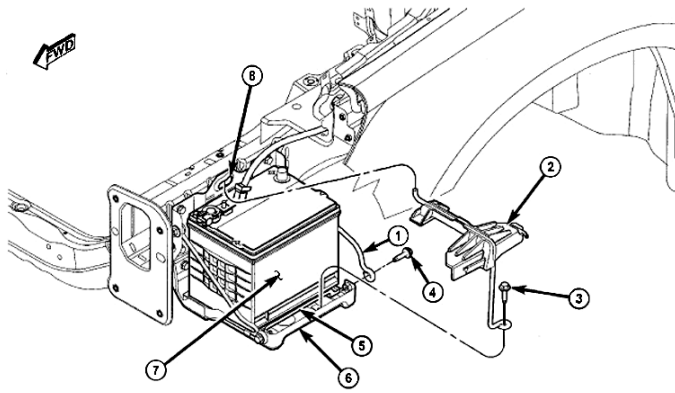

Fig. 2 Battery removal

BTY120000000591

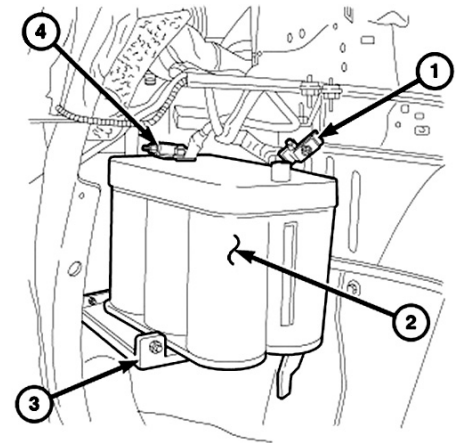

Fig. 3 Battery installation

BTY120000000592

The material herein may not be used without the prior express written permission of the copyright holder, including, but not limited to reproduction or transmission in any form by any means such as electronic, mechanical, photocopying, recording or otherwise; nor may it be stored on any retrieval system of any nature.

"The data reported herein has been compiled from authoritative sources. While every effort is made by the analysts to attain accuracy, manufacturing changes as well as typographical errors and omissions may occur on occasion. The publisher cannot be responsible nor does it assume any responsibility whatsoever for such omissions, errors or changes."

MOTOR INFORMATION SYSTEMS
MOTOR is a trademark of Hearst Business Media
A Unit of Hearst Corporation
1301 W. Long Lake, Suite 300
Troy, MI 48098

Copyright © 2012 Hearst Business Media. All rights reserved.