

CHEVROLET

2011-13 Corvette 6.2LSC

PRECAUTIONS

Warning: Batteries produce explosive gases, contain corrosive acid, and supply levels of electrical current high enough to cause burns. Therefore, to reduce the risk of personal injury when working near a battery: Always shield your eyes and avoid leaning over the battery whenever possible; do not expose the battery to open flames or sparks; do not allow the battery electrolyte to contact the eyes or the skin; flush immediately and thoroughly any contacted areas with water, and get medical help.

Warning: Unless directed otherwise, the ignition and start switch must be in the OFF or LOCK position, and all electrical loads must be OFF before servicing any electrical component. Disconnect the battery ground cable to prevent an electrical spark should a tool or equipment come in contact with an exposed electrical terminal. Failure to follow these precautions may result in personal injury and/or damage to the vehicle or its components.

For vehicles equipped with OnStar® (UE1) with Back Up Battery, the back up battery is a redundant power supply to allow limited OnStar® functionality in the event of a main vehicle battery power disruption to the VCIM (OnStar® module). Do not disconnect the main vehicle battery or remove the OnStar® fuse with the ignition key in any position other than OFF. Retained Accessory Power (RAP) should be allowed to time out or be disabled (simply opening the driver door should disable RAP) before disconnecting power. Disconnecting power to the OnStar® module in any way while the ignition is ON or with RAP activated may cause activation of the OnStar® Back Up Battery (BUB) system and will discharge and permanently damage the BUB. Once the BUB is activated, it will stay on until it has completely discharged. The BUB is not rechargeable and, once activated, the BUB must be replaced.

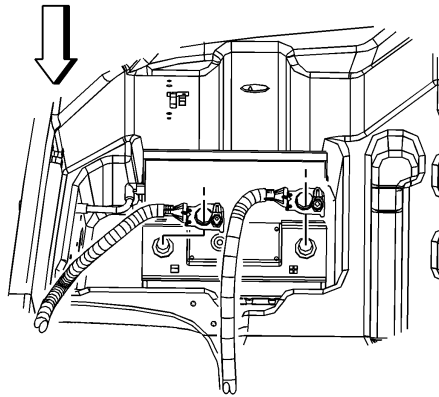

BTY120000000459

Fig. 1 Battery cable disconnection

BATTERY

Removal

Caution: When performing service on or near the SIR components or the SIR wiring, the SIR system must be disabled. Failure to observe the correct procedure could cause deployment of the SIR components, personal injury, or unrequired SIR system repairs.

1. Record radio anti-theft code and station presets.
2. Turn off all lamps and accessories.
3. Turn ignition switch to OFF position.
4. Open righthand rear compartment storage bin to access battery.
5. Disconnect battery vent hose.
6. Remove battery ground cable to battery nut and disconnect cable from battery, **Fig. 1**.
7. Disconnect battery positive cable from battery.
8. Remove battery hold down retainer nuts and retainer, **Fig. 2**.
9. Remove battery from vehicle.

Installation

Clean any existing oxidation from the contact face of the battery terminal and battery cable using a wire brush before installing the battery cable to the battery.

1. Install battery to vehicle.
2. Install battery hold down retainer and nuts, **Fig. 2**. **Torque** nuts to 13 ft. lbs.
3. Connect battery positive cable to battery. **Torque** battery cable bolt to 11 ft. lbs.
4. Connect battery ground cable to battery, **Fig. 1**.
5. Install battery ground cable nut, and **torque** to 71 inch lbs.
6. Close righthand rear compartment storage bin.
7. Reset all preset and theft codes previously recorded to radio.
8. Perform power window initialization as follows:
 - a. Close door for window being initialized.
 - b. Turn ignition to ON with engine off.
 - c. Run window to full up position and hold switch continuously for a minimum of 1/2 second.
 - d. Run window to full down position and hold switch continuously for a minimum of 1/2 second.
9. Perform memory seat calibration by operating seat adjuster switch in every direction until seat adjuster reaches its mechanical hard stop by repeatedly pressing and releasing switch as required.
10. Perform steering wheel and column calibration using a scan tool per manufacturer's instructions.
11. Refer to vehicle owner's manual for remote control door lock and theft deterrent transmitter key fob programming procedures.

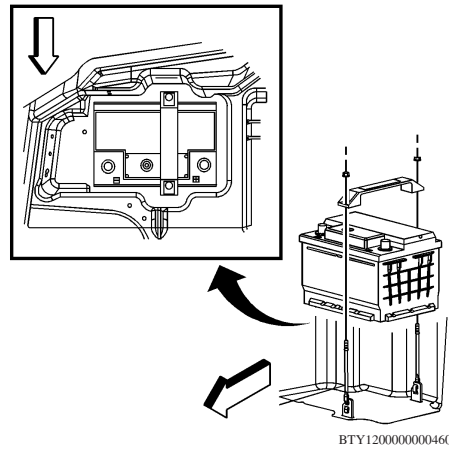

Fig. 2 Battery removal

The material herein may not be used without the prior express written permission of the copyright holder, including, but not limited to reproduction or transmission in any form by any means such as electronic, mechanical, photocopying, recording or otherwise; nor may it be stored on any retrieval system of any nature.

"The data reported herein has been compiled from authoritative sources. While every effort is made by the analysts to attain accuracy, manufacturing changes as well as typographical errors and omissions may occur on occasion. The publisher cannot be responsible nor does it assume any responsibility whatsoever for such omissions, errors or changes."

"Portions of materials herein have been reprinted with permission of General Motors LLC, Customer Care and Aftersales, License Agreement 1110717."

MOTOR INFORMATION SYSTEMS
MOTOR is a trademark of Hearst Business Media
A Unit of Hearst Corporation
1301 W. Long Lake, Suite 300
Troy, MI 48098

Copyright © 2015 Hearst Business Media. All rights reserved.
