

DCM0100



Outrageously Dependable™

DEEP CYCLE MOBILITY



DCM0100 VALVE-REGULATED LEAD-ACID BATTERY FOR DEEP-CYCLE APPLICATIONS

FEATURES

- Robust plate for extended cycle life
- Computer-generated grid design optimized for high-power density
- Low-calcium grid alloy for reduced gas emissions and ease of recycling
- Flame-arresting, one-way pressure-relief vent for safety and long life
- UL-recognized component
- Multicell design for economy of installation and maintenance
- Case and cover available in standard polypropylene
- Thermally welded case-to-cover bond to eliminate leakage
- Carrying handles
- Can be used in any orientation: upright, side or end mounting recommended
- Longest cycle life available
- Absorbed Glass Mat (AGM) technology for efficient gas recombination of up to 99% and freedom from electrolyte maintenance
- Not restricted for air transport — complies with IATA/ICAO Special Provision A67
- Not restricted for surface transport — classified as nonhazardous material as related to DOT-CFR Title 49 parts 173.159
- Not restricted for water transport — classified as nonhazardous material per IMDG Amendment 27
- Manufactured by an ISO9001 certified facility

12 Volts — 100 Amp-Hour
Capacity @ 20-Hour Rate

Ampere-Hour Capacity to 1.75 Volts per Cell @ 77° F (25° C) 10.5 Volts per 12 Volt Battery

	Approximate Discharge in Hours			
	20	10	5	1
Amp-Hour Capacity	100	95	76	52

Interstate Battery System International, Inc.

12770 Merit Drive, Suite 1000
Dallas, TX 75251
Customer Service: 1-888-772-3600

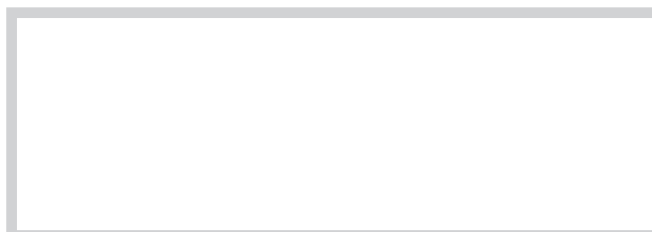

DCM0100



Outrageously Dependable™

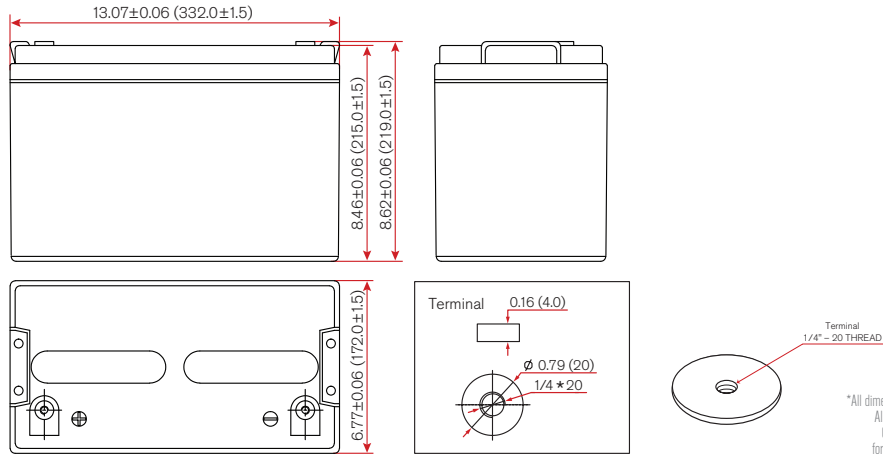

*All dimensions in inches and (millimeters).
All dimensions are for reference only.
Contact an Interstate representative
for complete dimensional information.

DEEP CYCLE MOBILITY

DCM0100 Specifications

Cells Per Unit	Voltage Per Unit	Weight	Electrolyte	Max. Discharge Current	Short Circuit Current	Ohms Imped. 60 Hz
6	12	65 lbs. 29.5 kg	Absorbed H ₂ SO ₄ SG = 1.30	500 Amps	1500 Amps @ 0.1 sec.	5 mΩ

Capacity	100 Ah @ 20 hr. rate to 1.75 volts per cell @ 77°F (25°C)
Operating Temperature Range (with temperature compensation)	Discharge: -40°F (-40°C) to +160°F (71°C) Charge: -10°F (-23°C) to +140°F (60°C)
Recommended Operating Temperature Range	+74°F (23°C) to +80°F (27°C)
Equalization and Cycle Service Charging and Current Limits	≤ 40 A, 14.5 V - 14.9 V
Float Voltage	13.5 - 13.8
Self Discharge	Interstate batteries may be stored for up to six months at 77°F (25°C), and then a freshening charge is required. For higher temperatures, the time interval will be shorter.
Terminal	Insert, threaded female, 1/4" - 20 (hardware included)

Constant Current Discharge Ratings

Amperes @ 77° F (25° C)													
End Point Volts/Cell	A: Amps W: Watts	5 min.	10 min.	15 min.	30 min.	1 hr.	2 hr.	3 hr.	4 hr.	5 hr.	8 hr.	10 hr.	20 hr.
9.60V	A	351.5	256.5	180.5	109.3	57	33.3	24.4	19	15.7	11	10	5.4
	W	3732.6	2818.7	1917.1	1160	660.3	384.8	283.1	220.4	181.5	128.3	115.9	62.4
10.20V	A	309.7	233.7	161.5	103.6	53.6	31.7	23.8	18.5	15.4	10.8	9.7	5.3
	W	3438.1	2594.5	1792.7	1149.5	620.4	367.7	275.5	214.7	178.1	125.4	113.1	60.8
10.50V	A	298.3	222.3	152	100.7	52.3	31	23.2	18.2	15.2	10.7	9.5	5.2
	W	3383	2521.3	1723.3	1141.9	600.4	359.1	268.9	210.9	175.8	124.5	111.2	60
10.80V	A	286.9	210.9	142.5	97.9	50.4	30.2	22.6	18	14.8	10.5	9.5	5.1
	W	3339.3	2454.8	1658.7	1139.1	584.3	351.5	263.2	207.1	172.9	121.6	110.2	59.8
11.10V	A	275.5	199.5	133	95	48.5	29.5	21.9	17.4	14.4	10.2	9	4.9
	W	3278.5	2374.1	1582.7	1130.5	576.7	350.6	260.3	206.2	172	120.7	107.4	58